



ENGINE

Make	FPT
Model	F2CFE614H
Emissions Certification	Tier 4 Final
Emissions Technology	SCR/DOC
Type	4-stroke, turbocharged and air-to-air cooled
Cylinders	6-cylinder in-line
Bore/Stroke	4.61 x 5.31 in (117 x 135 mm)
Displacement	531 in ³ (8.7 L)
Fuel	#2 Diesel, #1 and #2 mixture permitted for cold temperatures
Fuel injection	Direct injection – electronic
Fuel filter	Replaceable, spin-on cartridge
Fuel pump	Bosch CP 3.3
Gradeability:	
Side-to-side	35°
Fore and aft	35°
Air filter	2-element dry type w/ warning restriction indicator
Rear-mount cooling module w/ auto reversing fan:	
Rear-mount air/water w/ Lube Oil Cooler	
Fan – hydraulic driven:	
Style	9 blade puller
Diameter	36 in (914 mm)
Water pump	Integral
Engine oil pump operating angle ratings:	
Side-to-side	35°
Fore and aft	35°
Oil filtration	Replaceable, full flow spin-on cartridge
Engine speeds	RPM
Rated – full load	2100
Horsepower – Maximum Power:	
Peak gross @ 1800 RPM	318 hp (237 kW)
Net rated @ 2100 RPM	270 hp (201 kW)
Peak net @ 1800 RPM	304 hp (227 kW)
Torque – Maximum Power:	
Gross @ 1100 RPM	1,091 lb-ft (1 479 N-m)
Net @ 1100 RPM	1,057 lb-ft (1 433 N-m)

Net torque rise:

Maximum power range	57%
---------------------	-----

NOTE: Gross horsepower and torque per SAE J1995. Net horsepower and torque per SAE J1349.

DRIVETRAIN

Transmission:	4F/3R Proportional w/ Electronic Control Module torque sensing autoshift/manual shift and modulation	
Gears	Helical cut	
Gear ratios	Forward/Reverse	
1st	3.731/3.731	
2nd	2.207/2.207	
3rd	1.421/0.970	
4th	0.625/ —	
Torque converter:		
Stall ratio	3.089:1	
Differential:		
Front axle equipped w/ locking differential		
Rear axle equipped w/ open differential		
Rear axle oscillation	26° total	
Front and rear axles	Front/Rear:	
Differential ratio	4.25/4.50	
Planetary ratio	6.35/6.00	
Final axle ratio	27.00/27.00	
Planetaries	Outboard	
Service brakes:		
Hydraulically actuated, maintenance-free, multiple wet disc w/ accumulator to all four wheels		
Brake surface area:		
Front hub – each	1,144 in ² (0.738 m ²)	
Rear hub – each	841 in ² (0.542 m ²)	
Parking brakes:		
Spring-applied hydraulic release disc on transmission output shaft neutralizes power flow to wheels when engaged		

Travel speeds – 4-speed transmission:	Forward	Reverse
	mph (kph)	mph (kph)
1st	4.3 (7.0)	4.3 (7.0)
2nd	7.2 (11.6)	7.2 (11.6)
3rd	10.8 (17.4)	15.3 (24.6)
4th	22.0 (35.4)	—

NOTE: Travel speeds at full engine throttle w/ 26.5-R25 L3 Radial tires.

ELECTRICAL

Voltage	24 Volts, negative ground
Alternator	120 amp
Batteries (2)	12-volt

OPERATOR ENVIRONMENT

ROPS cab AC w/ heat; 8" LCD touchscreen display, adjustable armrest w/ 3 configurable buttons; Key start; Articulated power steering w/ tilt column; Fully adjustable, heated air-ride seat w/ head rest; AM/FM Bluetooth radio w/ auxiliary input; Cab convenience package: rear sun shade, interior mirror, under the seat drawer, 12V accessory port, & coat hook; Foot throttle; Single lever (joystick) loader control w/ fully adjustable wrist rest, 2 cup holders; 2 interior rear view mirrors; 3 inch (76 mm) retractable seat belt;

Integrated 4-corner strobe; Multiple storage trays; Single brake pedal; F/N/R shuttle switch; Left and Right external rear view mirrors; Sound suppression kit; Pressurized air filtering; Anti-glare window strip; Front and Rear Defroster; Side window, partial/fully open; 2 Dome lights; Wipers, rear and intermittent front; Windshield washers, front and rear; Rubber floor mat; Horn.

Displays/Gauges:

Digital:

Transmission oil temperature; Engine coolant temperature; Fuel level; DEF level.

LCD screen:

Hour meter; Time; FNR indication; Trip computer A/B; Metric/english; Differential lock; Engine speed; Automatic trans indication; DeClutch indication; Fuel consumption; Engine diagnostics; Error reporting; Travel speed; Current gear selection; Engine mode indication; Multiple languages; Transmission diagnostics; Warning prompts.

Audible/Visual alarms:

Warning lights:

Four-way flashers and turn signals; Brake pressure; Lamp/high beam indication; Engine block heater.

Caution warnings:

Parking brake; Coolant temperature; Hydraulic oil temperature; Transmission oil temperature; Air filter; Transmission filter; Hydraulic filter; Alternator; Low fuel.

Critical warnings:

Engine oil pressure; Brake pressure; Steering pressure – w/ aux. steering*; Coolant temperature; Hydraulic oil temperature; Transmission oil temperature.

Backup alarm

Maintenance reminders:

Cab air filter; Engine oil filter; Fuel pre-filter; DEF tank vent filter; SCR supply filter; Hydraulic oil and filter; Engine air filter; Engine coolant; Drive belt; Cab recirculation filter; Engine breather filter; Transmission breather; Front and rear axle fluid; SCR supply module filter.

NOTE: *If equipped w/ option.

OPERATING WEIGHT

Z-Bar

Unit equipped w/ ROPS cab w/ heater and A/C; Standard counterweight; 26.5-R25 L3 Radial tires; 5.5 yd³ (4.2 m³) GP pin-on w/ bolt on edge; Full fuel; 165 lb (75 kg) operator: 56,365 lb (25 567 kg)

XR

Unit equipped w/ ROPS cab w/ heater and A/C; Standard counterweight; 26.5-R25 L3 Radial tires; 5.5 yd³ (4.2 m³) HD pin-on w/ bolt on edge; Full fuel; 165 lb (75 kg) operator: 58,711 lb (26 631 kg)

HYDRAULICS

Main pumps – steering/implement:

Closed center pressure/flow compensated

Tandem variable displacement – load-sensing

Max. rated flow P1: 50.2 gpm @ 2000 RPM
(190 L/min @ 2000 RPM)

Max. rated flow P2: 42.8 gpm @ 2000 RPM
(162 L/min @ 2000 RPM)

Loader control valve:

Closed-center, sectional 2, 3 or 4-function
w/ control for lift, tilt and auxiliary hydraulics

Loader auxiliary steering:

Hydraulic orbital center-pivot articulating
w/ on-demand oil flow

High pressure standby:

Implement 3,650 psi (25 165 kPa)

Steering 3,495 psi (24 097 kPa)

Filtration:

Filtered vent w/ relief on hydraulic reservoir,
maintains 3-5 psi on reservoir, 10-micron,
return filter furnishes only clean oil to all
components of the system

SERVICE CAPACITIES

Fuel tank 125 gal (473.0 L)

DEF tank – Diesel Exhaust Fluid:

Usable capacity 16 gal (61.0 L)

Total 24 gal (90.8 L)

Hydraulic system:

Reservoir 35.4 gal (134 L)

Total 66 gal (250 L)

Transmission:

Service w/ filter 48.0 qt (45.4 L)

Front and rear axle:

Front axle 65.5 qt (62 L)

Rear axle 44.4 qt (42 L)

Engine oil w/ filter 30 qt (28.5 L)

Cooling system 15 gal (56.8 L)

OTHER SPECIFICATIONS

Lift cylinder:

Bore diameter 7.00 in (177.8 mm)

Rod diameter 4.50 in (114.3 mm)

Stroke 30.73 in (780.6 mm)

Dump cylinder – Z-Bar and XR:

Bore diameter 8.00 in (203.2 mm)

Rod diameter 5.00 in (127.0 mm)

Stroke 22.91 in (581.9 mm)

Loader:

Z-Bar loader linkage; Single control for
lift and tilt; Positive hold float; Automatic
return-to-dig; Automatic height control;
Automatic return-to-travel; Brake pedal
transmission disconnect; Bucket position
indicator on bucket.

Cycle time:

Raise w/ rated bucket load 6.2 sec

Dump w/ rated bucket load 1.3 sec

Float down 2.8 sec

Sound level in Cab (LpA) 69 dB(A)

Exterior sound level (LwA) 105 dB(A)

NOTE: Sound level data tested in accordance
with ISO6395, 6396, 3744.

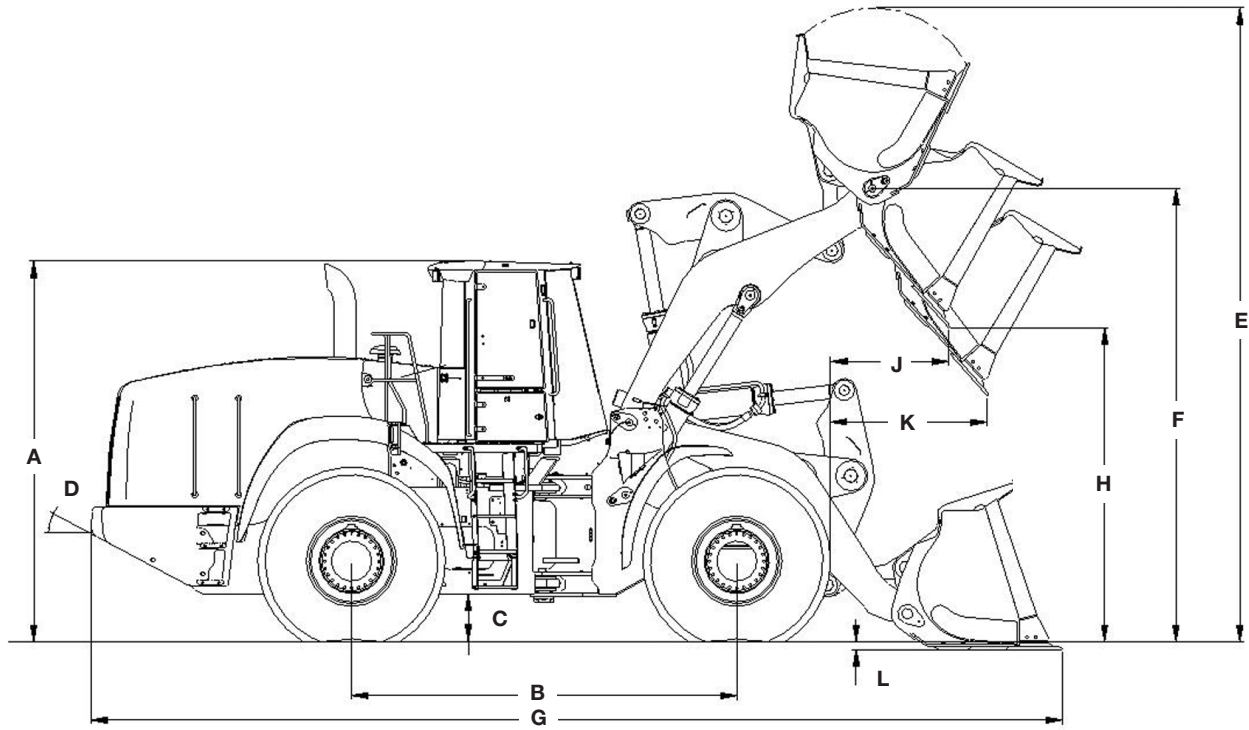

Line drawings are for illustrative purpose only and may not be exact representation of unit.

DIMENSIONS

A. Height to top of ROPS cab	140.8 in (3 577 mm)
Height to drawbar	45.0 in (1 143 mm)
B. Wheelbase	139.8 in (3 550 mm)
C. Ground clearance	17.2 in (437 mm)
D. Angle of departure	23°
Width:	
Overall* without bucket	117.2 in (2 978 mm)
Tread width	90.6 in (2 300 mm)
Turning radius* – outside	250.6 in (6 366 mm)
Turning angle:	
From center	40°
Total angle	80°
Rear axle oscillation – total	26°

NOTE: *Dimensions taken with 26.5-R25 L3 Radial tires. Additional dimensions on pages 4 through 5.

WEIGHT ADJUSTMENTS

Select Options	Weight Adjustment	Tipping Load Adjustment Straight: Deflected*	Tipping Load Adjustment 40° Turn: Deflected*
26.5 x 25 L5 Radial Tires	+1,500 lb (+680 kg)	+1,179 lb (+535 kg)	+1,056 lb (+479 kg)

NOTE: Unit equipped with Z-Bar loader arms, 5.5 yd³ (4.2 m³) pin on bucket w/ bolt-on edge, 26.5-R25 L3 Radial tires, ROPS cab with heater and A/C, full counterweight, front and rear fenders, full fuel and 165 lb (75 kg) operator. Adjust select options from rated weight.

*Tipping loads: ISO 14397-1 Deflected Tires.

PERFORMANCE SPECS

1021G Z-Bar*		5.5 yd³ (4.2 m³) Bucket with Bolt-on Edge - Pin On	5.3 yd³ (4.1 m³) Bucket with Teeth - Pin On
Operating weight		56,365 lb (25 567 kg)	56,361 lb (25 565 kg)
E.	Operating height – fully raised with spillguard	229.3 in (5 824 mm)	229.3 in (5 824 mm)
F.	Hinge pin height – fully raised	167.2 in (4 246 mm)	167.2 in (4 246 mm)
G.	Overall length – bucket level on ground	352.3 in (8 948 mm)	359.4 in (9 130 mm)
Dump angle – fully raised		53°	53°
H.	Dump height – fully raised, 45° dump	121.2 in (3 078 mm)	116.5 in (2 959 mm)
J.	Bucket reach – fully raised, 45° dump	49.8 in (1 265 mm)	55.1 in (1 399 mm)
K.	Bucket reach – 7 ft 0 in (2.13 m) height, 45° dump	74.3 in (1 888 mm)	77.5 in (1 969 mm)
L.	Dig depth	4.9 in (123 mm)	5.0 in (128 mm)
Operating load – ISO Rigid Tires		19,560 lb (8 872 kg)	19,694 lb (8 933 kg)
Operating load – ISO Deflected Tires		17,858 lb (8 100 kg)	17,980 lb (8 155 kg)
Maximum material density – ISO Rigid Tires		3,556 lb/yd ³ (2 110 kg/m ³)	3,716 lb/yd ³ (2 205 kg/m ³)
Maximum material density – ISO Deflected Tires		3,247 lb/yd ³ (1 927 kg/m ³)	3,392 lb/yd ³ (2 013 kg/m ³)
Tipping load – ISO Rigid Tires:			
	Straight	48,196 lb (21 861 kg)	48,523 lb (22 010 kg)
	40° turn	39,121 lb (17 745 kg)	39,389 lb (17 866 kg)
Tipping load – ISO Deflected Tires:			
	Straight	45,126 lb (20 469 kg)	45,428 lb (20 606 kg)
	40° turn	35,717 lb (16 201 kg)	35,959 lb (16 311 kg)
Lift capacity:			
	Full height	31,048 lb (14 083 kg)	30,993 lb (14 058 kg)
	Ground	52,015 lb (23 593 kg)	52,533 lb (23 829 kg)
Breakout force with tilt cylinder		45,056 lb (20 437 kg)	48,219 lb (21 872 kg)
Loader clearance circle with bucket		558.2 in (14 177 mm)	563.1 in (14 303 mm)

1021G XR		5.5 yd³ (4.2 m³) Bucket with Bolt-on Edge - Pin On	5.3 yd³ (4.1 m³) Bucket with Teeth - Pin On
Operating weight		58,711 lb (26 631 kg)	58,707 lb (26 629 kg)
E.	Operating height – fully raised with spillguard	252.2 in (6 405 mm)	252.2 in (6 405 mm)
F.	Hinge pin height – fully raised	190.0 in (4 827 mm)	190.0 in (4 827 mm)
G.	Overall length – bucket level on ground	372.7 in (9 467 mm)	379.8 in (9 648 mm)
Dump angle – fully raised		50°	50°
H.	Dump height – fully raised, 45° dump	144.1 in (3 659 mm)	139.4 in (3 541 mm)
J.	Bucket reach – fully raised, 45° dump	50.3 in (1 278 mm)	55.6 in (1 411 mm)
K.	Bucket reach – 7 ft 0 in (2.13 m) height, 45° dump	92.8 in (2 358 mm)	96.3 in (2 446 mm)
L.	Dig depth	5.0 in (127 mm)	5.2 in (131 mm)
Operating load – ISO Rigid Tires		16,208 lb (7 352 kg)	16,308 lb (7 397 kg)
Operating load – ISO Deflected Tires		15,259 lb (6 921 kg)	15,346 lb (6 961 kg)
Maximum material density – ISO Rigid Tires		2,947 lb/yd ³ (1 749 kg/m ³)	3,077 lb/yd ³ (1 826 kg/m ³)
Maximum material density – ISO Deflected Tires		2,774 lb/yd ³ (1 646 kg/m ³)	2,896 lb/yd ³ (1 718 kg/m ³)
Tipping load – ISO Rigid Tires:			
	Straight	39,366 lb (17 856 kg)	39,620 lb (17 971 kg)
	40° turn	32,416 lb (14 703 kg)	32,615 lb (14 794 kg)
Tipping load – ISO Deflected Tires:			
	Straight	37,816 lb (17 153 kg)	38,047 lb (17 258 kg)
	40° turn	30,518 lb (13 843 kg)	30,692 lb (13 922 kg)
Lift capacity:			
	Full height	27,746 lb (12 585 kg)	27,705 lb (12 567 kg)
	Ground	41,798 lb (18 959 kg)	42,153 lb (19 120 kg)
Breakout force with tilt cylinder		45,493 lb (20 635 kg)	48,698 lb (22 089 kg)
Loader clearance circle with bucket		578.1 in (14 684 mm)	583.7 in (14 826 mm)

1021G	Z-Bar/XR	Z-Bar/XR
Maximum rollback:		
	Ground	44°/42°
	Carry position	49°/48°
	@ Full height	65°/66°
Maximum grading angle with bucket – back dragging		60°/62°
SAE bucket capacity – struck	4.75 yd ³ (3.63 m ³)	4.56 yd ³ (3.49 m ³)
Heaped	5.50 yd ³ (4.21 m ³)	5.30 yd ³ (4.05 m ³)
Bucket width – outside	125.8 in (3 195 mm)	126.9 in (3 223 mm)
Bucket weight	4,676 lb (2 121 kg)	4,672 lb (2 119 kg)

NOTE: *Z-Bar performance data shown with full counterweight. 6.5-R25 L3 Radial tires, ROPS cab w/ heater and A/C, standard counterweight, full fuel and 165 lb (75 kg) operator. Specifications per SAE J732, J1234, J695, J742, and J818.

STANDARD EQUIPMENT

OPERATOR ENVIRONMENT

See page 1

ENGINE

CASE/FPT F2CFE614H
Tier 4 Final Certified
Selective Catalytic Reduction (SCR) with Diesel Oxidation Catalyst
Selectable work modes:
 Maximum Mode
 Smart Mode
Automatic shutdown – idle reduction device
Turbocharger
Charge air cooling
Automatic fan belt tensioner
Integral engine oil cooling
Fuel filter with water trap
Dual-element dry-type air cleaner
Hydraulic-driven cooling fan
Air-cooled radiator
Rear-mounted cooling module with hydraulically driven auto-reversing fan
Engine block heater
Sound suppression kit
Ejector type air precleaner
Common rail electronic fuel injection

LOADER

See page 2 – Operating weight,
Other specifications

DRIVETRAIN

4-wheel drive
4F/3R Selectable autoshift/manual shift transmission
Electronic Control Module – programmable, computer controlled proportional shifting with programmable gear selection
Onboard diagnostics
Heavy-duty axles:
 With locking front differential and open/conventional rear differential
Single lever electronic shift control
F/N/R switch in loader control handle
Downshift button
Torque converter
Outboard planetary axles
Transmission oil cooler
Brake pedal transmission disconnect
Hydraulic wet disc brakes
Spring-applied hydraulic release parking brake
Limp-Home Mode
Greaseable rear axle trunnion

HYDRAULICS

Adjustable Electro-hydraulic – EH loader control with 3 configurable buttons
Adjustable EH settings:
 Smooth
 Moderate
 Aggressive
Ride Control™
EH Parallel Lift
Low-effort steering
Hydraulic driven fan
8 Diagnostic quick couplers
Split flange hydraulic connections – 1 inch or greater
Hydraulic oil cooler

ELECTRICAL

Battery isolator/electrical disconnect
120 amp alternator and voltage regulator
(2) 1000 CCA 12-volt batteries
Electric starter
Lights:
 Integrated 4-corner strobe
 Front and rear halogen flood lights
 2 Front driving headlights – high/low beam
 2 Front flood
 2 Rear flood
 2 LED stop and tail lights
 Front and rear turn signal/flash
Key start/stop switch
Centrally located fuse box with all electrical circuits protected
Backup alarm
Remote jump start posts

OTHER

Electric hood lift
Front and rear fenders, partial coverage
External rear view mirrors
Standard counterweight
Drawbar hitch
Articulation locking bar
Lift arm locking bar
Lift and tie-down points – front/rear
Backup alarm
3-piece rims
Rear frame side covers
License plate brackets; front bracket and lit rear bracket
Rubber steering stops
Standard fenders with Left hand and Right hand steps
Grouped remote-mounted ecology drains:
 Engine oil
 Engine coolant
 Hydraulic oil

TELEMATICS

CASE SiteWatch™ Telematics – includes hardware and a 3-yr Advanced data subscription
SiteConnect Module provides remote diagnostics capability

OPTIONAL EQUIPMENT

OPERATOR ENVIRONMENT

- Leather trimmed heated air seat with active suspension
- In cab powered cooler box
- In cab accessory mount
- Rear view camera
- External heated rear view mirrors
- Front LED driving/headlights
- LED front and rear work lights – 4 front, 2 rear

DRIVETRAIN

- Axle coolers
- Axle oscillation stops
- Cold weather package:
 - Fuel heater
 - Hydraulic oil cooler bypass
 - Low temperature hydraulic oil
 - Grid heater

HYDRAULICS

- Auxiliary hydraulics
- Secondary steering
- Integrated Payload System
- Tire Pressure Monitoring System
- 2-function EH loader control with one auxiliary function
- 4-function EH loader control with two proportional auxiliary controls
- 2 Single axis EH levers and one auxiliary function
- Joystick steering with or without secondary steering

LOADER

- XR extended reach version
- Attachment auxiliary hydraulics
- Buckets – see page 4

TIRES

- 26.5 x 25 L3 Bias
- 26.5-R25 L3 Radial
- 26.5 x 25 L5 Bias
- 26.5-R25 L5 Radial

OTHER

- 12 mph (20 kph) maximum speed control
- Special paint
- Wide full coverage fenders with right and left hand steps

CaseCE.com

©2021 CNH Industrial America LLC. All rights reserved. CASE is a trademark registered in the United States and many other countries, owned by or licensed to CNH Industrial N.V., its subsidiaries or affiliates. CNH Industrial Capital is a trademark in the United States and many other countries, owned by or licensed to CNH Industrial N.V., its subsidiaries or affiliates. Printed in U.S.A. Contains 10% post-consumer fiber.

IMPORTANT: CASE Construction Equipment Inc. reserves the right to change these specifications without notice and without incurring any obligation relating to such change. Availability of some models and equipment builds vary according to the country in which the equipment is used. The illustrations and text may include optional equipment and accessories and may not include all standard equipment. Your CASE dealer/distributor will be able to give you details of the products and their specifications available in your area.



CASE Construction Equipment is biodiesel-friendly. NOTE: All engines meet current EPA emissions regulations. All specifications are stated in accordance with SAE Standards or Recommended Practices, where applicable.



Always read the Operator's Manual before operating any equipment. Inspect equipment before using it, and be sure it is operating properly. Follow the product safety signs and use any safety features provided.

Form No. CCE2021041021G
Replaces Form No. CCE2020021021G

1021G

6 of 6