



ENGINE

Model	Isuzu AR-4JJ1X CEGR, SCR, DOC
Emissions Certification	Tier 4 Final
Fuel	Requires ultra-low sulfur fuel B5 biodiesel tolerant
Type	Water-cooled, 4-cycle, high pressure common rail system Turbocharger w/ air cooled intercooler, SCR system
Cylinders	4-cylinder in-line
Displacement	183 in ³ (3 L)
Bore/Stroke	3.76 x 4.13 in (95.4 x 104.9 mm)
Fuel injection	Direct injection – electronic
Fuel filter	Replaceable, full flow spin-on cartridge
Air filter	Dry type element w/ warning restriction indicator
Oil filter	Replaceable, full flow spin-on cartridge
Engine gradeability:	
Side-to-side	35°
Fore and aft	35°
Net horsepower – SAE J1349 @ 2000 RPM:	102 hp (76.4 kW)
Net max. torque – SAE J1349 @ 1800 RPM:	257 lbf-ft (349 N-m)
Cooling operating range:	109° to -13°F (43° to -25°C)
Oil	Requires low-ash oil CJ-4

DRIVETRAIN

Travel control	Dual stage relief/ counter balance design
Brakes	Mechanical disc
Service brakes	SAHR disc – each motor
Two speed travel:	
Max. high speed	3.5 mph (5.6 km/h)
Max. low speed	2.1 mph (3.4 km/h)
Automatic downshift	
Drawbar pull	26,100 lbf (116 kN)
Gradeability	70% – 35° Slope

ELECTRICAL

Voltage	24 Volts
Alternator rating	50 amp
Batteries	2 x 12 Volt
Battery reserve capacity	72 Ah/5 hour
Work lights – 4 1 boom, 1 upper, 2 cab	24 Volt/70 watt

OPERATOR ENVIRONMENT

Air conditioner output	18,100 BTU/hr
Heater output	20,150 BTU/hr
Sound level inside cab – ISO6395	70 dBA
Electrical outlet	12 Volt
Cab interior light	10 watt
Rear view camera	Standard
Seat	Heated, air-suspension

ATTACHMENT

Boom	15 ft 2 in (4 630 mm)
Arm options	8 ft 2 in (2.5 m) 9 ft 10 in (3.01 m) 6 ft 11 in (2.11 m)
Bucket digging force w/ auto power up	20,200 lbf (90 kN) 21,400 lbf (95 kN)

NOTE: *Digging force ratings based on ISO6015.

OPERATING WEIGHT

Operating weight	30,400 lb (13 800 kg)
w/ shoes	2 ft 0 in (600 mm)
w/ boom	15 ft 2 in (4 630 mm)
w/ arm	8 ft 2 in (2.5 m)
w/ bucket	882 lb (400 kg)
w/ counterweight	4,380 lb (1 990 kg)
w/ blade	8 ft 6 in (2 590 mm)

NOTE: W/ operator/full fuel/standard equipment.

GROUND PRESSURE

@ Standard operating weight 5.4 psi (0.37 bar)
w/ 23.6 in (600 mm) triple grouser shoes

HYDRAULICS

System design	Open center
Main pumps	Two-variable displacement/ axial piston
Max. rated flow per pump:	34.1 gpm (129 L/min) @ 2000 RPM
Max. rated flow total:	68.2 gpm (258 L/min) @ 2000 RPM
System pressures:	
Boom, arm and bucket	4,970 psi (343 bar)
w/ Power Boost	5,260 psi (363 bar)
Travel circuits	4,970 psi (343 bar)
Swing circuits	4,050 psi (279 bar)
Pilot pump	1 x gear design
Max. capacity	5.3 gpm (20 L/min)

Controls	w/ boom/arm holding valve
Right track travel, bucket, boom and arm acceleration.	1 x Four-spool section
Left track travel, auxiliary, swing, boom and arm acceleration.	1 x Five-spool section

Work mode selections	SP: Speed Priority H: Heavy-Duty A: Automatic
----------------------	---

Swing motor	Fixed displacement axial piston
Swing final drive	Planetary gear reduction
Travel motor	Two-speed independent travel/axial piston

HYDRAULIC CYLINDERS

Boom cylinders	Two (2)
Cylinder bore	4.1 in (105 mm)
Cylinder rod diameter	2.8 in (70 mm)
Cylinder stroke	37.8 in (961 mm)

Arm cylinder	One (1)
Cylinder bore	4.5 in (115 mm)
Cylinder rod diameter	3.1 in (80 mm)
Cylinder stroke	43.6 in (1 108 mm)

Bucket cylinder	One (1)
Cylinder bore	3.7 in (95 mm)
Cylinder rod diameter	2.6 in (65 mm)
Cylinder stroke	34.7 in (881 mm)

Blade cylinder	One (1)
Cylinder bore	4.5 in (115 mm)
Cylinder rod diameter	2.8 in (70 mm)
Cylinder stroke	9.8 in (250 mm)

SERVICE CAPACITIES

Fuel tank	69 gal (260 L)
Hydraulic system	41 gal (157 L)
Hydraulic tank	22 gal (82 L)
Engine oil w/ filter	4.5 gal (17 L)
Swing drive	0.6 gal (2.2 L)
Final drive	0.6 gal (2.1 L)
Cooling system	4.7 gal (17.7 L)
DEF tank	20 gal (75 L)

OTHER SPECIFICATIONS

Swing speed	14.3 RPM
Swing torque	24,400 lbf-ft (33 000 kN-m)
Swing brake	Mechanical disc
Undercarriage:	
Length	11 ft 6 in (3 500 mm)
Track gauge	6 ft 6 in (1 990 mm)
Carrier rollers – each side	1
Track rollers – each side	7
Shoes – triple grouser – each side	43
Shoe width – std.	2 ft 0 in (600 mm)
Link pitch	6.8 in (172 mm)
Track:	
Chain	Grease lubricated/strutted
Guides	Single
Adjustment	Hydraulic

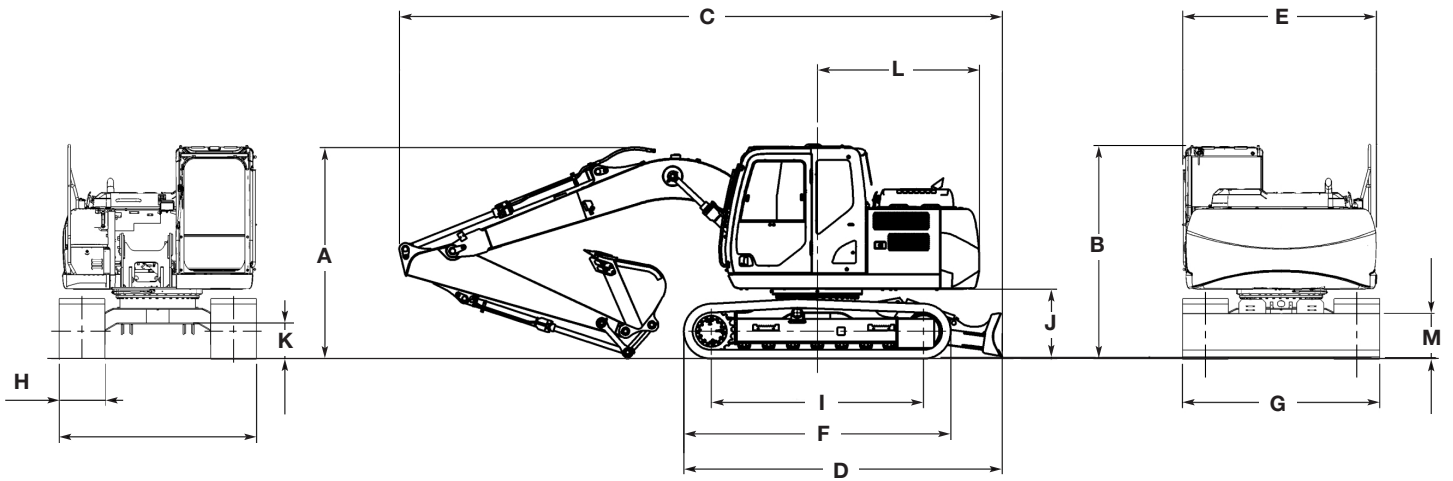

Line drawings are for illustrative purpose only and may not be exact representation of unit.

DIMENSIONS

	8 ft 2 in (2.50 m) Arm	9 ft 10 in (3.01 m) Arm	6 ft 11 in (2.11 m) Arm
A. Overall height	9 ft 1 in (2 770 mm)	8 ft 8 in (2 640 mm)	8 ft 10 in (2 680 mm)
B. Cab height	9 ft 3 in (2 830 mm)	9 ft 3 in (2 830 mm)	9 ft 3 in (2 830 mm)
C. Overall length – with attachment	25 ft 11 in (7 900 mm)	25 ft 11 in (7 900 mm)	25 ft 11 in (7 890 mm)
D. Overall length – without attachment	13 ft 8 in (4 160 mm)	13 ft 8 in (4 160 mm)	13 ft 8 in (4 160 mm)
E. Width of upper structure	8 ft 4 in (2 530 mm)	8 ft 4 in (2 530 mm)	8 ft 4 in (2 530 mm)
F. Track overall length	11 ft 6 in (3 500 mm)	11 ft 6 in (3 500 mm)	11 ft 6 in (3 500 mm)
G. Track overall width with 23.6 in (600 mm) shoes	8 ft 6 in (2 590 mm)	8 ft 6 in (2 590 mm)	8 ft 6 in (2 590 mm)
H. Track shoe width	2 ft 0 in (600 mm)	2 ft 0 in (600 mm)	2 ft 0 in (600 mm)
I. Center to center – idler to sprocket	9 ft 2 in (2 790 mm)	9 ft 2 in (2 790 mm)	9 ft 2 in (2 790 mm)
J. Upper structure ground clearance	2 ft 11 in (895 mm)	2 ft 11 in (895 mm)	2 ft 11 in (895 mm)
K. Minimum ground clearance	1 ft 5 in (425 mm)	1 ft 5 in (425 mm)	1 ft 5 in (425 mm)
L. Rear tail swing radius	7 ft 1 in (2 170 mm)	7 ft 1 in (2 170 mm)	7 ft 1 in (2 170 mm)
M. Blade height	1 ft 10 in (570 mm)	1 ft 10 in (570 mm)	1 ft 10 in (570 mm)

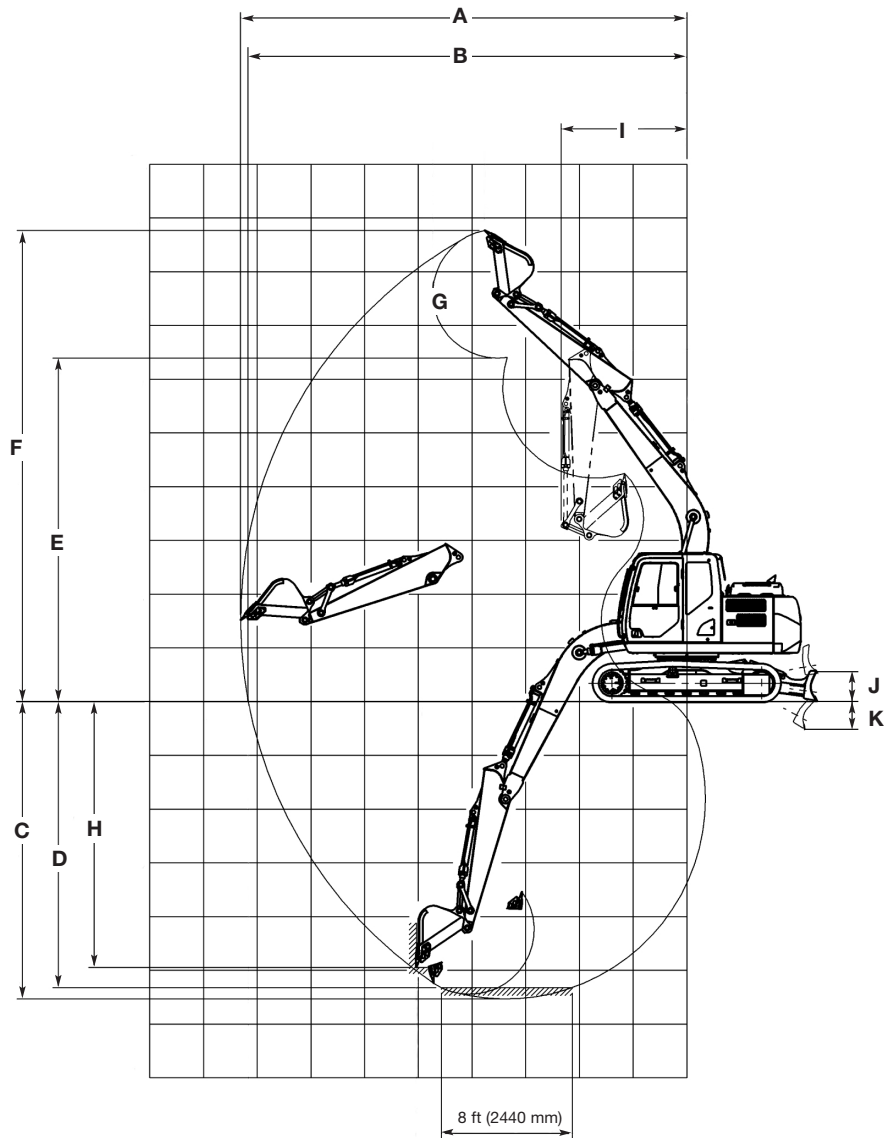

PERFORMANCE SPECS

	8 ft 2 in (2.50 m) Arm	9 ft 10 in (3.01 m) Arm	6 ft 11 in (2.11 m) Arm
A. Maximum dig radius	27 ft 3 in (8 310 mm)	28 ft 9 in (8 770 mm)	26 ft 1 in (7 960 mm)
B. Dig radius at groundline	26 ft 10 in (8 170 mm)	28 ft 4 in (8 640 mm)	25 ft 7 in (7 810 mm)
C. Maximum dig depth	18 ft 3 in (5 550 mm)	19 ft 10 in (6 050 mm)	16 ft 11 in (5 160 mm)
D. Dig depth – 8 ft 0 in (2.44 m) level bottom	17 ft 6 in (5 330 mm)	19 ft 3 in (5 870 mm)	16 ft 2 in (4 920 mm)
E. Dump height	21 ft 0 in (6 390 mm)	21 ft 11 in (6 680 mm)	20 ft 3 in (6 170 mm)
F. Maximum reach height	28 ft 9 in (8 770 mm)	29 ft 8 in (9 050 mm)	28 ft 1 in (8 550 mm)
G. Bucket rotation	178°	178°	178°
H. Maximum vertical wall dig depth	16 ft 3 in (4 950 mm)	17 ft 7 in (5 350 mm)	15 ft 1 in (4 600 mm)
I. Minimum swing radius	7 ft 8 in (2 340 mm)	8 ft 9 in (2 660 mm)	7 ft 9 in (2 360 mm)
J. Blade maximum lift above ground	1 ft 8 in (510 mm)	1 ft 8 in (510 mm)	1 ft 8 in (510 mm)
K. Blade maximum drop below ground	1 ft 9 in (520 mm)	1 ft 9 in (520 mm)	1 ft 9 in (520 mm)
Arm digging force:			
Standard	13,900 lbf (62 kN)	12,600 lbf (56 kN)	15,700 lbf (70 kN)
Power Boost	14,800 lbf (66 kN)	13,500 lbf (60 kN)	16,600 lbf (74 kN)
Bucket digging force:			
Standard	20,200 lbf (90 kN)	20,200 lbf (90 kN)	20,200 lbf (90 kN)
Power Boost	21,400 lbf (95 kN)	21,400 lbf (95 kN)	21,400 lbf (95 kN)

LIFT CAPACITIES

8 ft 2 in (2.50 m) Arm, Lift capacities using a 900 lb (408 kg) bucket, 4,850 lb (2 200 kg) counterweight.

Load (Lift Point Height)	5 ft (1.5 m)		10 ft (3 m)		15 ft (4.5 m)		20 ft (6 m)		25 ft (7.5 m)		MAXIMUM REACH		
	END	SIDE	END	SIDE	END	SIDE	END	SIDE	END	SIDE	@	END	SIDE
+25 ft (7.5 m)					4,050 lb (1 837 kg)	4,050 lb (1 837 kg)					16 ft 7 in (5.05 m)	3,250 lb (1 474 kg)	3,250 lb (1 474 kg)
+20 ft (6 m)					5,900 lb (2 676 kg)	5,900 lb (2 676 kg)	4,950 lb (2 245 kg)	4,750 lb (2 155 kg)			21 ft 9 in (6.63 m)	2,700 lb (1 225 kg)	2,700 lb (1 225 kg)
+15 ft (4.5 m)					6,400 lb (2 903 kg)	6,400 lb (2 903 kg)	6,100 lb (2 767 kg)	4,700 lb (2 132 kg)			24 ft 7 in (7.49 m)	2,550 lb (1 157 kg)	2,550 lb (1 157 kg)
+10 ft (3 m)			11,550 lb (5 239 kg)	11,550 lb (5 239 kg)	8,600 lb (3 901 kg)	7,250 lb (3 289 kg)	6,950 lb (3 152 kg)	4,500 lb (2 041 kg)	4,750 lb (2 155 kg)	3,000 lb (1 361 kg)	26 ft 0 in (7.92 m)	2,550 lb (1 157 kg)	2,550 lb (1 157 kg)
+5 ft (1.5 m)			16,800 lb (7 620 kg)	12,700 lb (5 761 kg)	10,700 lb (4 853 kg)	6,700 lb (3 039 kg)	6,700 lb (3 039 kg)	4,250 lb (1 928 kg)	4,650 lb (2 109 kg)	2,850 lb (1 293 kg)	26 ft 4 in (8.03 m)	2,700 lb (1 225 kg)	2,600 lb (1 179 kg)
Groundline	5,650 lb (2 563 kg)	5,650 lb (2 563 kg)	18,450 lb (8 369 kg)	11,700 lb (5 307 kg)	10,300 lb (4 672 kg)	6,300 lb (2 858 kg)	6,500 lb (2 948 kg)	4,000 lb (1 814 kg)	4,550 lb (2 064 kg)	2,800 lb (1 270 kg)	25 ft 7 in (7.80 m)	3,000 lb (1 361 kg)	2,700 lb (1 225 kg)
-5 ft (-1.5 m)	11,200 lb (5 080 kg)	11,200 lb (5 080 kg)	20,200 lb (9 163 kg)	11,600 lb (5 262 kg)	10,100 lb (4 581 kg)	6,100 lb (2 767 kg)	6,350 lb (2 880 kg)	3,900 lb (1 769 kg)			23 ft 9 in (7.24 m)	3,600 lb (1 633 kg)	3,000 lb (1 361 kg)
-10 ft (-3 m)	17,700 lb (8 029 kg)	17,700 lb (8 029 kg)	18,550 lb (8 414 kg)	11,850 lb (5 375 kg)	10,200 lb (4 627 kg)	6,200 lb (2 812 kg)	6,500 lb (2 948 kg)	4,050 lb (1 837 kg)			20 ft 7 in (6.27 m)	4,900 lb (2 223 kg)	3,850 lb (1 746 kg)
-15 ft (-4.5 m)			13,800 lb (6 260 kg)	12,150 lb (5 511 kg)	8,250 lb (3 742 kg)	6,450 lb (2 926 kg)					15 ft 4 in (4.67 m)	7,800 lb (3 538 kg)	6,200 lb (2 812 kg)

9 ft 10 in (3.01 m) Arm, Lift capacities using a 750 lb (340 kg) bucket, 4,850 lb (2 200 kg) counterweight.

Load (Lift Point Height)	0 ft (0 m)		5 ft (1.5 m)		10 ft (3 m)		15 ft (4.5 m)		20 ft (6 m)		25 ft (7.5 m)		MAXIMUM REACH		
	END	SIDE	END	SIDE	END	SIDE	END	SIDE	END	SIDE	END	SIDE	@	END	SIDE
+25 ft (7.5 m)													19 ft 1 in (5.82 m)	3,100 lb (1 406 kg)	3,100 lb (1 406 kg)
+20 ft (6 m)									4,900 lb (2 223 kg)	4,900 lb (2 223 kg)			23 ft 7 in (7.19 m)	2,700 lb (1 225 kg)	2,700 lb (1 225 kg)
+15 ft (4.5 m)									5,800 lb (2 631 kg)	4,850 lb (2 200 kg)	4,200 lb (1 905 kg)	3,150 lb (1 429 kg)	26 ft 3 in (8.00 m)	2,550 lb (1 157 kg)	2,550 lb (1 157 kg)
+10 ft (3 m)							7,500 lb (3 402 kg)	7,300 lb (3 311 kg)	6,550 lb (2 971 kg)	4,600 lb (2 087 kg)	4,850 lb (2 200 kg)	3,050 lb (1 383 kg)	27 ft 7 in (8.41 m)	2,550 lb (1 157 kg)	2,500 lb (1 134 kg)
+5 ft (1.5 m)					14,450 lb (6 554 kg)	13,100 lb (5 942 kg)	10,200 lb (4 627 kg)	6,850 lb (3 107 kg)	6,800 lb (3 084 kg)	4,300 lb (1 950 kg)	4,700 lb (2 132 kg)	2,900 lb (1 315 kg)	27 ft 10 in (8.48 m)	2,700 lb (1 225 kg)	2,350 lb (1 066 kg)
Groundline			5,850 lb (2 654 kg)	5,850 lb (2 654 kg)	18,650 lb (8 459 kg)	11,800 lb (5 352 kg)	10,350 lb (4 695 kg)	6,300 lb (2 858 kg)	6,500 lb (2 948 kg)	4,050 lb (1 837 kg)	4,550 lb (2 064 kg)	2,800 lb (1 270 kg)	27 ft 2 in (8.28 m)	3,000 lb (1 361 kg)	2,400 lb (1 089 kg)
-5 ft (-1.5 m)	8,400 lb (3 810 kg)	8,400 lb (3 810 kg)	10,200 lb (4 627 kg)	10,200 lb (4 627 kg)	20,100 lb (9 117 kg)	11,450 lb (5 194 kg)	10,050 lb (4 559 kg)	6,050 lb (2 744 kg)	6,350 lb (2 880 kg)	3,900 lb (1 769 kg)	4,500 lb (2 041 kg)	2,750 lb (1 247 kg)	25 ft 5 in (7.75 m)	3,500 lb (1 588 kg)	2,700 lb (1 225 kg)
-10 ft (-3 m)	11,200 lb (5 080 kg)	11,200 lb (5 080 kg)	15,100 lb (6 849 kg)	15,100 lb (6 849 kg)	19,300 lb (8 754 kg)	11,600 lb (5 262 kg)	10,050 lb (4 559 kg)	6,100 lb (2 767 kg)	6,400 lb (2 903 kg)	3,950 lb (1 792 kg)			22 ft 6 in (6.86 m)	4,600 lb (2 087 kg)	3,300 lb (1 497 kg)
-15 ft (-4.5 m)			24,050 lb (10 909 kg)	24,050 lb (10 909 kg)	15,800 lb (7 167 kg)	12,050 lb (5 466 kg)	10,150 lb (4 604 kg)	6,450 lb (2 926 kg)					17 ft 9 in (5.41 m)	7,400 lb (3 357 kg)	4,850 lb (2 200 kg)

6 ft 11 in (2.11 m) Arm, Lift capacities using a 900 lb (408 kg) bucket, 4,850 lb (2 200 kg) counterweight.

Load (Lift Point Height)	5 ft (1.5 m)		10 ft (3 m)		15 ft (4.5 m)		20 ft (6 m)		25 ft (7.5 m)		MAXIMUM REACH		
	END	SIDE	END	SIDE	END	SIDE	END	SIDE	END	SIDE	@	END	SIDE
+25 ft (7.5 m)											14 ft 6 in (4.42 m)	4,000 lb (1 814 kg)	4,000 lb (1 814 kg)
+20 ft (6 m)					6,300 lb (2 858 kg)	6,300 lb (2 858 kg)	4,050 lb (1 837 kg)	4,050 lb (1 837 kg)			20 ft 3 in (6.17 m)	3,300 lb (1 497 kg)	3,300 lb (1 497 kg)
+15 ft (4.5 m)					7,150 lb (3 243 kg)	7,150 lb (3 243 kg)	6,550 lb (2 971 kg)	4,550 lb (2 064 kg)			23 ft 4 in (7.11 m)	3,050 lb (1 383 kg)	3,050 lb (1 383 kg)
+10 ft (3 m)			12,350 lb (5 602 kg)	12,350 lb (5 602 kg)	9,250 lb (4 196 kg)	7,050 lb (3 198 kg)	6,850 lb (3 107 kg)	4,350 lb (1 973 kg)			24 ft 10 in (7.57 m)	3,050 lb (1 383 kg)	2,900 lb (1 315 kg)
+5 ft (1.5 m)			17,400 lb (7 893 kg)	12,250 lb (5 557 kg)	10,600 lb (4 808 kg)	6,550 lb (2 971 kg)	6,600 lb (2 994 kg)	4,150 lb (1 882 kg)	3,950 lb (1 792 kg)	2,800 lb (1 270 kg)	25 ft 2 in (7.67 m)	3,200 lb (1 451 kg)	2,750 lb (1 247 kg)
Groundline			16,800 lb (7 620 kg)	11,450 lb (5 194 kg)	10,150 lb (4 604 kg)	6,150 lb (2 790 kg)	6,400 lb (2 903 kg)	3,950 lb (1 792 kg)			24 ft 5 in (7.44 m)	3,550 lb (1 610 kg)	2,850 lb (1 293 kg)
-5 ft (-1.5 m)	12,100 lb (5 488 kg)	12,100 lb (5 488 kg)	19,850 lb (9 004 kg)	11,550 lb (5 239 kg)	10,050 lb (4 559 kg)	6,050 lb (2 744 kg)	6,350 lb (2 880 kg)	3,900 lb (1 769 kg)			22 ft 6 in (6.86 m)	4,300 lb (1 950 kg)	3,250 lb (1 474 kg)
-10 ft (-3 m)	18,600 lb (8 437 kg)	18,600 lb (8 437 kg)	17,500 lb (7 938 kg)	11,850 lb (5 375 kg)	10,200 lb (4 627 kg)	6,250 lb (2 835 kg)					19 ft 1 in (5.82 m)	6,000 lb (2 722 kg)	4,300 lb (1 950 kg)
-15 ft (-4.5 m)											11 ft 7 in (3.53 m)	9,800 lb (4 445 kg)	9,500 lb (4 309 kg)

NOTE: *Following number indicates hydraulic capacity

STANDARD EQUIPMENT

ENGINE

Isuzu AR-4JJ1X
Tier 4 Final Certified
Selective Catalytic Reduction – SCR
Diesel Oxidation Catalyst – DOC
Cooled Exhaust Gas Recirculation – CEGR
EGR Coolers
Four-cylinder turbo-charged diesel
VGT turbocharger
Electronic fuel injection
High pressure common rail system
Neutral safety start
Auto-engine warm up
Glow-plug pre-heat
Fuel Economy Assist System – FEA
Engine Protection Feature – EPF
Dual-stage fuel filtration
Dual element air filter
Remote oil filter
Drain for fuel tank
Remote engine oil drain
500-hour engine oil change interval
24 Volt system
Engine oil sample port
Battery disconnect switch
Emergency engine stop
External Fuel and DEF gauges
Fan housing
Fuel cooler
Fuel filter restriction indicator
Fuel shut-off valve
Idle start
Radiator, oil cooler,
intercooler – protective screen

FUEL ECONOMY SYSTEMS

Engine Idle/Fuel Economy System:
Auto-idle
One-touch idle
Auto-idle shut-down
BEC – Boom Economy Control
AEC – Auto Economy Control
SWC – Swing Relief Control
SSC – Spool Stroke Control

HYDRAULICS

Auto power boost
Auto swing priority
Arm speed assistance – 2 pump flow
Auxiliary flow control
Auxiliary valve
Boom speed assistance – 2 pump flow
Bucket curl assist
Control levers pre-wired for
auxiliary hydraulics
Electronically controlled hydraulic pumps
Holding valve – Boom and Arm
Fire wall
Hydraulic filter restriction indicator
Neutral pump de-stroke
Oil cooler

Power save
Pump stand-by pressure
Auto travel speed change
Selectable work modes
Free swing
Hydraulic oil sample port
Control pattern selector
Pre-set auxiliary pump settings
Auxiliary valve
5,000-hour hydraulic oil change interval
1,000-hour hydraulic filter change interval
SAHR brake

UPPER STRUCTURE

ISO mirrors – 3
Viscous Cab mounts – fluid and spring
Upper mounted work light – 70 watt
Swivel guard belly pan
Center cover – over main CV
Fuel tank belly pan
Handrail – RH access
ISO guard rails
Lifting eyes for counterweight
Lockable fuel cap, service doors and tool box

ATTACHMENTS

Boom – 15 ft 2 in (4.63 m)
Arm – 8 ft 2 in (2.50 m)
Heavy-duty bucket linkage
Boom mounted work light – 70 watt
Auxiliary pipe brackets
Centralized grease fittings
Attachment cushion valve
Arm and boom regeneration
Bucket anti-clatter device
Chrome pins
Easy Maintenance System (EMS) bushings
Teardrop pin retention keepers

OPERATOR ENVIRONMENT

ROPS protection
FOPS cab top guard – Level 1
Pressurized cab
Face vent
Cab lights – 2
Interior dome light
One-touch lock front window
One piece window – right
Safety glass windows
Gate lock hydraulic activation
Emergency exit and hammer
Clear polycarbonate roof window
with sunshade
AC/heat/defrost with auto climate control
LED Color monitor – 7 in (180 mm)
26 selectable languages for monitor
On-board diagnostic system
10 programmable attachments settings on
monitor – 5 single flow, 5 dual flow
Seatbelt – 3 in (76 mm)
Heated high-back cloth seat with air
suspension and 65° tilt adjustment
Sliding seat – 3.54 in (90 mm)

Adjustable armrests
Tilting consoles – 4-position
Sliding cockpit – 3.15 in (80 mm)
Low-effort joystick controls
Controls pre-wired for auxiliary
Straight travel
AM/FM radio with antenna, 2 speakers and
Bluetooth capabilities
Aux-in port for personal electronics
Radio mute switch – joystick
Rear-view camera
Anti-theft system – start code system
Rubber floor mat
12 Volt electric outlet
24 Volt cigarette lighter
Windshield wiper/washer
Cup holder
Storage compartments
Warm/cool storage compartment
Travel alarm with cancel switch
Ignition keys
One key start & lock-up
Cab filter – external
Cab handrails
Operator's manual

UNDERCARRIAGE

23.6 in (600 mm) steel shoes,
triple semi-grouser
Full overlap turntable bearing tub
Track chain guides
Hydraulic track adjustment
Sealed link chain
Steps
Carbody belly pan – swivel guard
X-pattern carbody
Lashing points – tie downs

FRONT DOZER BLADE

8 ft 6 in (2.59 m) width – comes with
23.6 in (600 m) steel shoes

TELEMATICS

CASE SiteWatch™ Telematics – includes
hardware and a 3-yr Advanced
data subscription

OPTIONAL EQUIPMENT

ENGINE

Refueling pump

HYDRAULICS

Auxiliary hydraulics:

Single acting/joystick activated

Double acting/joystick activated – thumb

Multi-function with electronic pressure control/joystick activated with

electronic proportional controls

Secondary low-flow/joystick activated

Proportional hydraulic controls

Hose Burst Check Valve – HBCV

MACHINE CONTROL

Leica iCON iXE2 – 2D System

Leica iCON iXE3 – 3D System

ATTACHMENTS

Heavy-duty arm – 6 ft 11 in (2.11 m)

Long arm – 9 ft 11 in (3.01 m)

Quick coupler/Case multi-pin grabber

Tools:

Heavy-duty/Extreme-duty/Ditching

Buckets; Hammers; Thumbs;

Compaction plates.

Load holding control

UPPER STRUCTURE

Rubber bumper guard – order through Service Parts

UNDERCARRIAGE

19.7 in (500 mm) rubber link chain, bolt-on rubber pads on steel chain

27.6 in (700 mm) steel shoes, triple semi-grouser

Double track chain guides

OPERATOR ENVIRONMENT

FOPS cab top guard – Level 2

Front grill guard – 2 x 2 in (50.8 x 50.8 mm) screen mesh

Front rock guard – vertical bars

Two piece/OPG 1

Front rock guard – vertical bars

One piece/OPG 2

Vandal guard (front window) with common key

Rain deflector – not available with Front guards

Sun visor

Side-view camera

LED Package:

Includes 1 Side view camera and 6 LED

Lights – 2 front cab mounted, 2 rear mounted and 1 mounted on each side

FRONT DOZER BLADE

Hydraulically controlled front dozer blade:

8 ft 2 in (2.49 m) width – comes with

19.7 in (500 mm) rubber link chain

8 ft 10 in (2.69 m) width – comes with

27.6 in (700 mm) steel shoes

CaseCE.com

©2021 CNH Industrial America LLC. All rights reserved. CASE is a trademark registered in the United States and many other countries, owned by or licensed to CNH Industrial N.V., its subsidiaries or affiliates. CNH Industrial Capital is a trademark in the United States and many other countries, owned by or licensed to CNH Industrial N.V., its subsidiaries or affiliates. Printed in U.S.A. Contains 10% post-consumer fiber.

IMPORTANT: CASE Construction Equipment Inc. reserves the right to change these specifications without notice and without incurring any obligation relating to such change. Availability of some models and equipment builds vary according to the country in which the equipment is used. The illustrations and text may include optional equipment and accessories and may not include all standard equipment. Your CASE dealer/distributor will be able to give you details of the products and their specifications available in your area.



CASE Construction Equipment is biodiesel-friendly. NOTE: All engines meet current EPA emissions regulations. All specifications are stated in accordance with SAE Standards or Recommended Practices, where applicable.



Always read the Operator's Manual before operating any equipment. Inspect equipment before using it, and be sure it is operating properly. Follow the product safety signs and use any safety features provided.

Form No. CCE202106CX130D

Replaces Form No. CCE201807CX130D

CX130D

6 of 6